

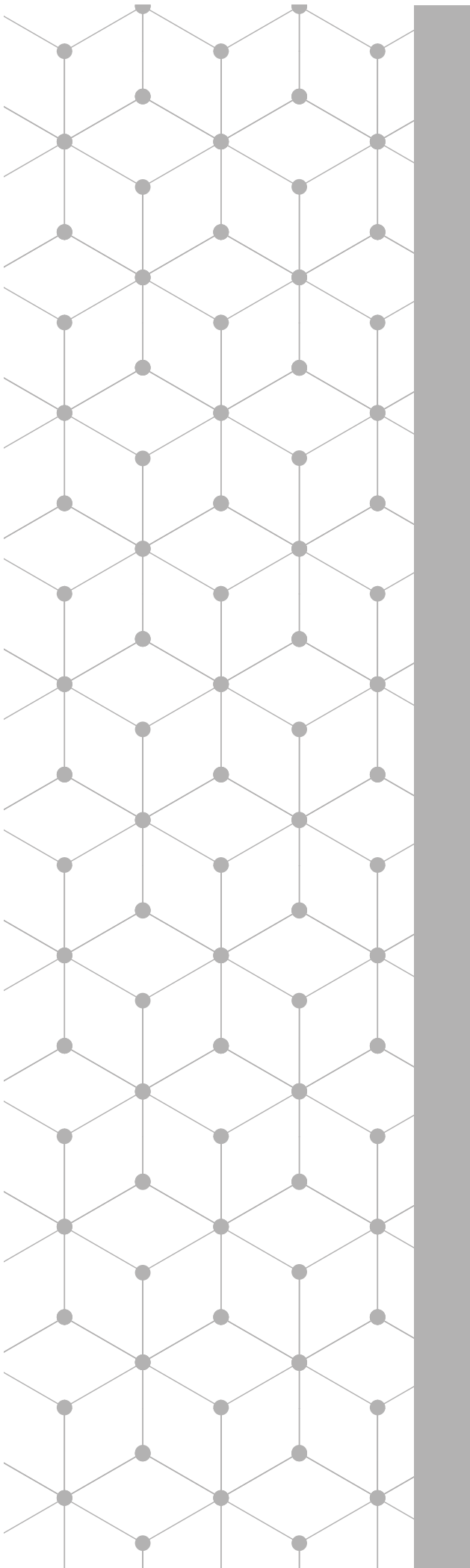

SLIDE50





SH System Holz

SLIDE50



SLIDE50

Sistema scorrevole per ante interne

Gli ammortizzatori montati nei binari non richiedono nessuna lavorazione sulle ante e sulla struttura del mobile lasciando libero lo spazio all'interno dell'armadio.

Il binario a incasso è utilizzabile con pannelli dello spessore minimo di 18mm.

I Carrelli sono dotati di molle anti-scarrucolamento e di un dispositivo di sgancio/rilascio della ruota per un montaggio e smontaggio rapido e sicuro dell'anta.

Portata: 50 kg/anta. Regolazione verticale dell'anta 6 mm.

Sliding system for internal doors

Dampers mounted inside the rails do not require any working on the doors and on the cabinet, leaving free all the space inside the wardrobe.

The small-size built-in rail can be used with standard panels of 18mm minimum thickness.

Rollers are equipped with anti-derailment springs and with a locking/release device for a safe and easy mounting and dismantling of the door.

Loading capacity: 50 kg / door. Vertical adjustment 6 mm.

- * AMMORTIZZATORE INCORPORATO
Built-in damper
- * REGOLAZIONE VERTICALE 6MM
6mm vertical adjustment
- * BINARI INCASSATI ED ESTERNI
Embedded and external rails

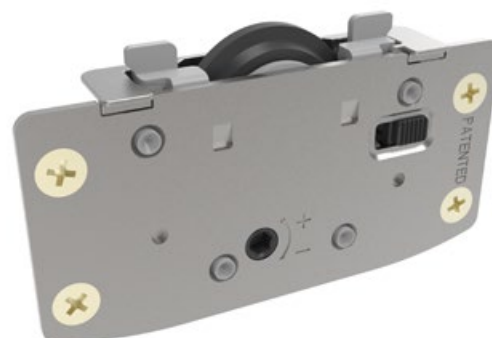

BINARI E CARRELLI INCASSATI / Recessed rails and rollers

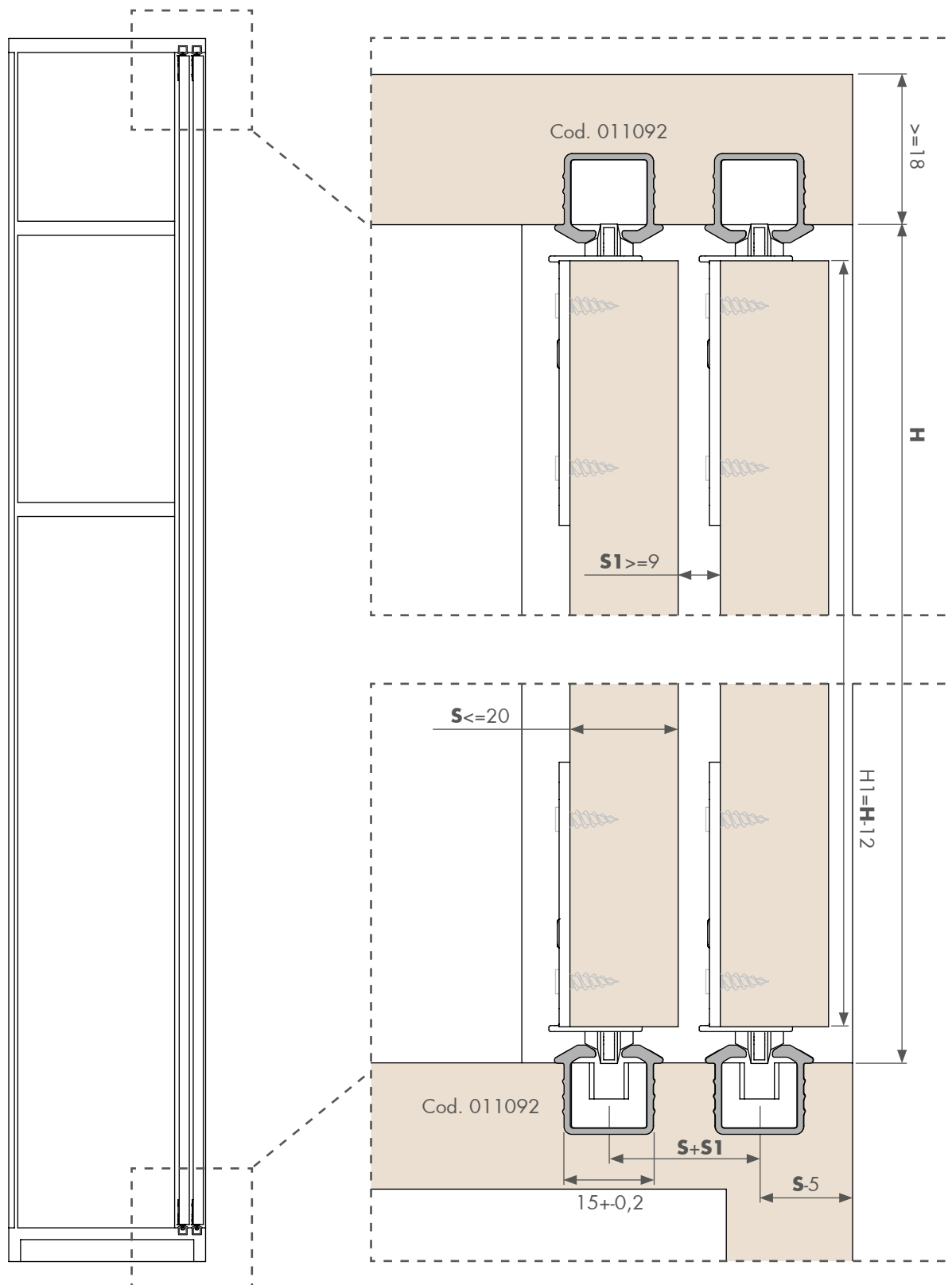

CARRELLI E BINARI ESTERNI / External rollers and rails

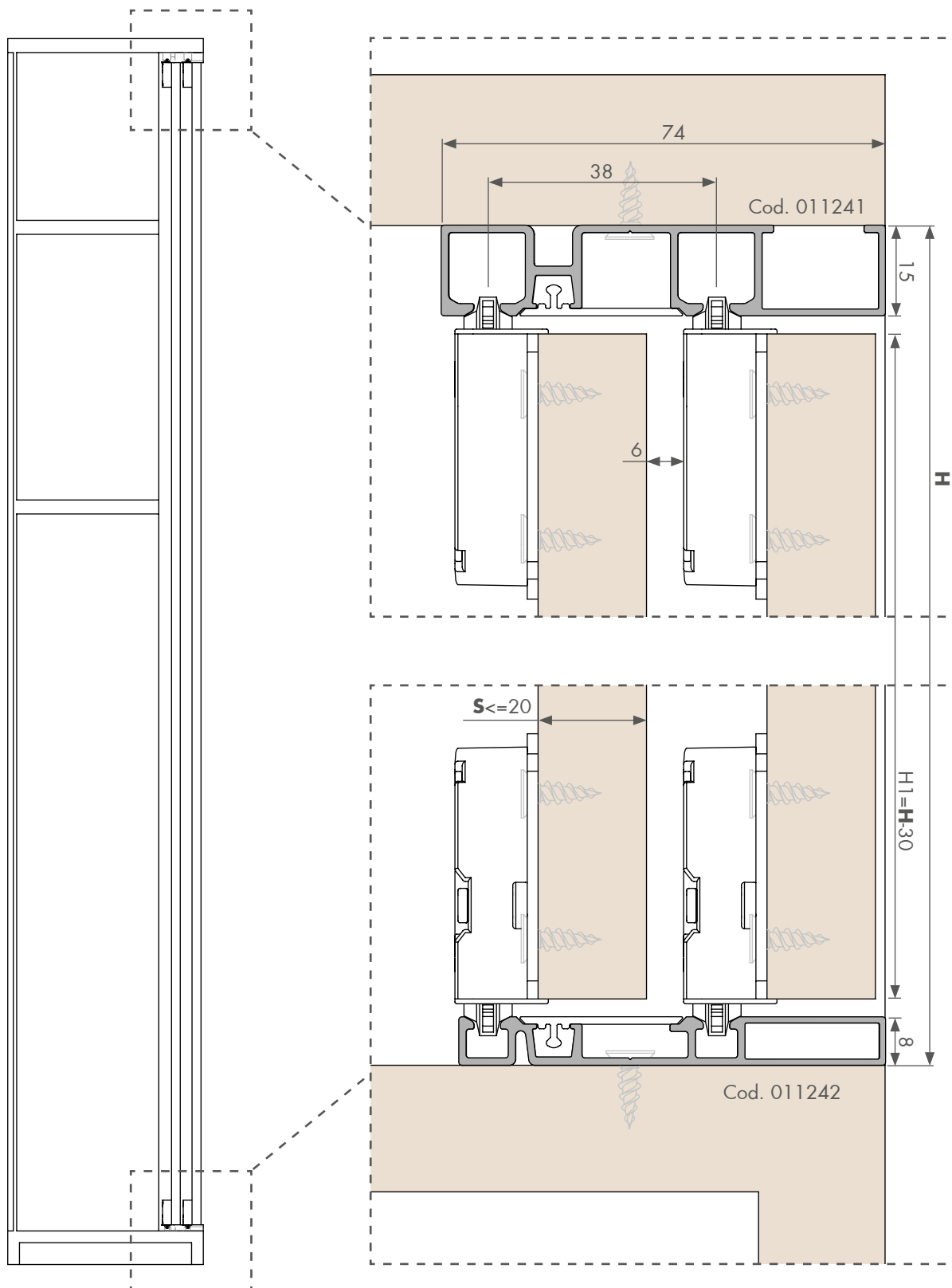

MONTAGGIO CARRELLI / Rollers install

CARRELLI INCASSATI
Embedded rollers

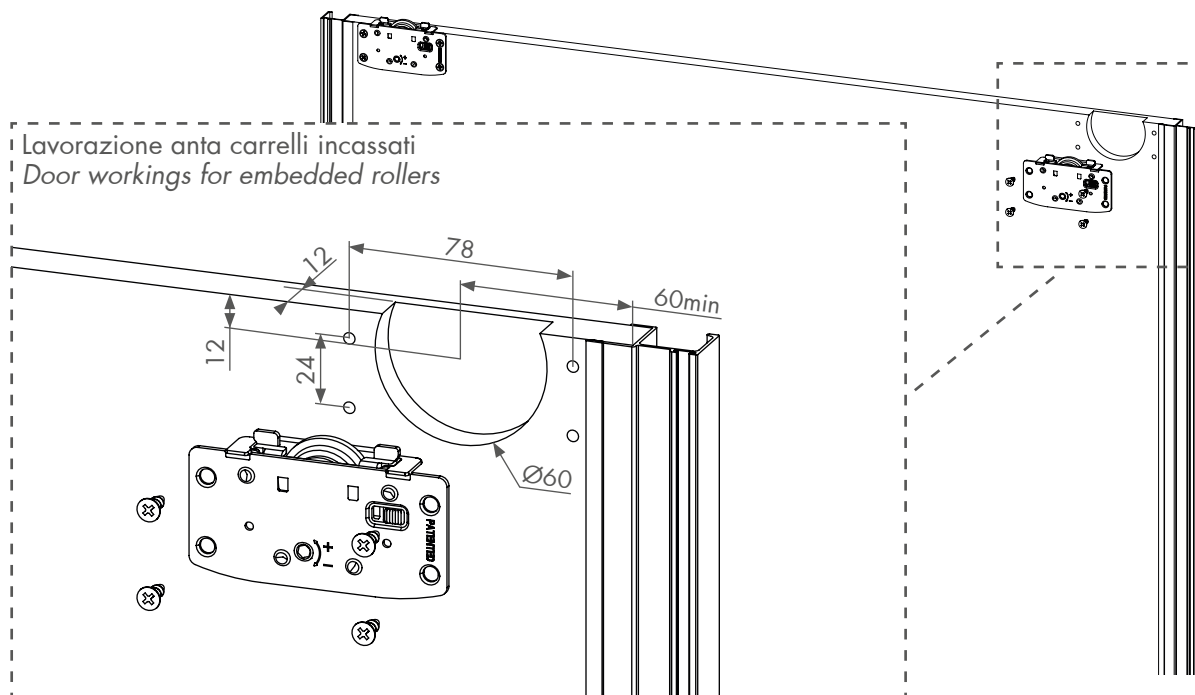

MONTAGGIO CARRELLI / Rollers install

CARRELLI ESTERNI

External rollers

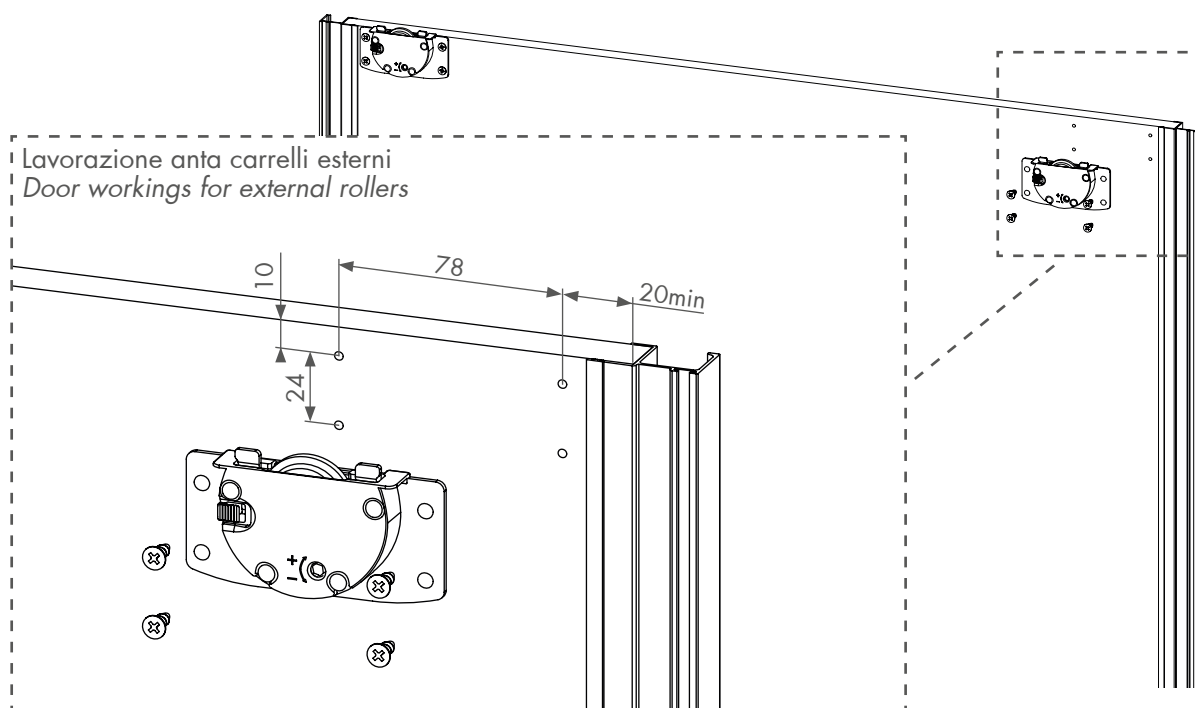

COMPONENTI / *Parts list*

KIT ANTA SOFT CLOSING

Soft closing door kit

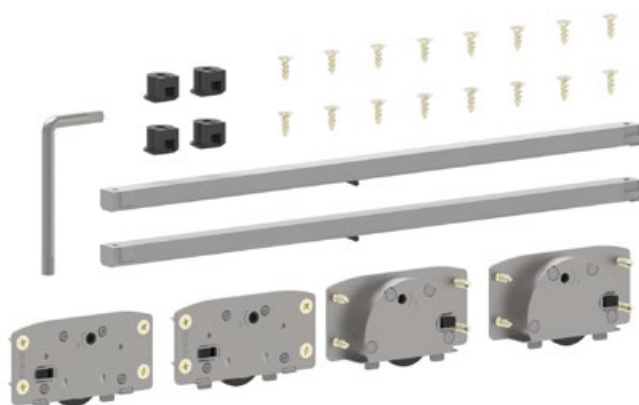

4 carrelli / *rollers*
2 ammortizzatori / *damper*
4 tappi / *end plugs*
16 viti di fissaggio / *fixing screws*
1 chiave / *allen key*

Cod. **000K416----**0

KIT ANTA

Door kit



4 carrelli / *rollers*
4 tappi / *end plugs*
16 viti di fissaggio / *fixing screws*
1 chiave / *allen key*

Cod. **000K417----**0

COMPONENTI E KIT / *Parts list and kit*



011092

BINARIO SUPERIORE ED INFERIORE INCASSATO
Upper and lower embedded rail

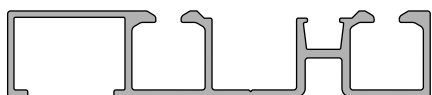

011241

BINARIO SUPERIORE ESTERNO
Upper external rail



011242

BINARIO INFERIORE ESTERNO
Lower external rail

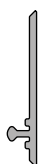

011243

COVER PER BINARI ESTERNI
Cover for external rails

ALL THE FURNITURE HARDWARE



POZZI ferramenta

Più di 30.000 articoli commercializzati per il settore della ferramenta per mobili con oltre 64 paesi serviti.
More than 30.000 products marketed of furniture accessories with over 64 countries served.

SH System Holz

Produttore specializzato nello sviluppo di cerniere per mobili, sistemi scorrevoli e profili e ante in alluminio.
Manufacturer specializing in the development of hinges for furniture, sliding systems and aluminium doors and profile.

QS OXIDAL SYSTEM

Leader nella pulitura e ossidazione anodica di particolari in alluminio con 37 vasche e 2 forni di asciugatura.
Leading company in any type of surface treatment on aluminium materials, with 37 baths and 2 drying ovens.

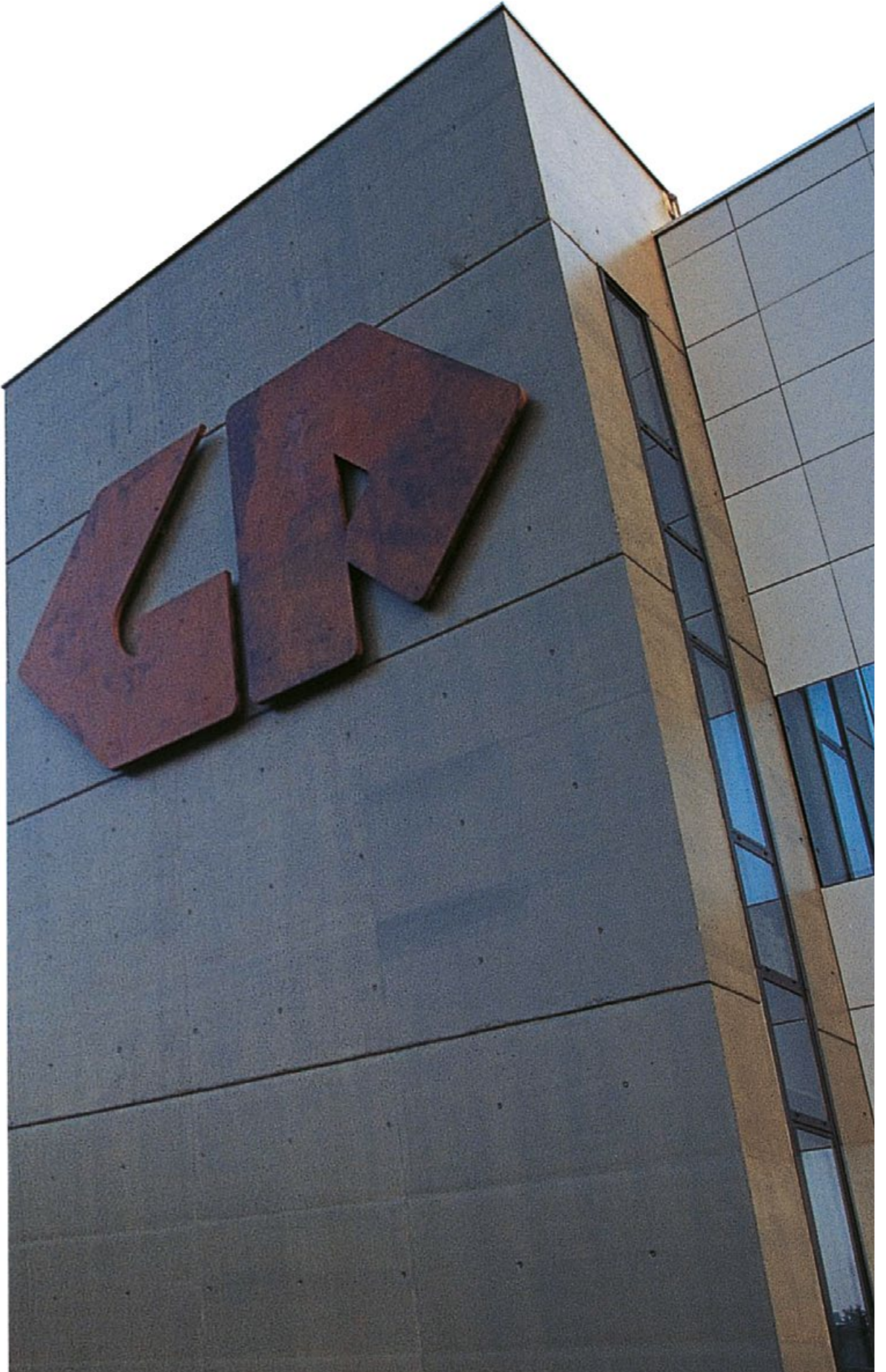

SH System Holz

SYSTEM HOLZ SRL

Via Valsorda, n.6
22040 Cremnago di Inverigo, (CO) ITALY
Tel. +39 031 6949111 - Fax. +39 031 698073
infosh@gruppopozzi.it - www.gruppopozzi.it



Gruppo Pozzi